

FAN-CLUB



Nr. 26
ZUM SAMMELN

CLUBMODELL:
"Kranwagen"

Wir feiern 40 Jahre Fischertechnik. Aus diesem Grund haben wir dieses Mal ein Modell nach alter und einfacher Bauweise entwickelt. So sehen Modelle in den Anfängen von Fischertechnik aus – verändert mit den klassischen Farben grau und rot. Unser Kranwagen ist mit einer Dreischmelenkung und einer Seilwinde mit Schneckenantrieb ausgerüstet. Das Fahren ist motorisiert. Gebaut wurde das Modell aus dem neuen Baukasten „Advanced Classic“ (Art.: 94781) und dem „Mini Motor Set“ (Art.: 30342).

Download von:
www.ft-fanarchiv.de



fischertechnik



Kranwagen

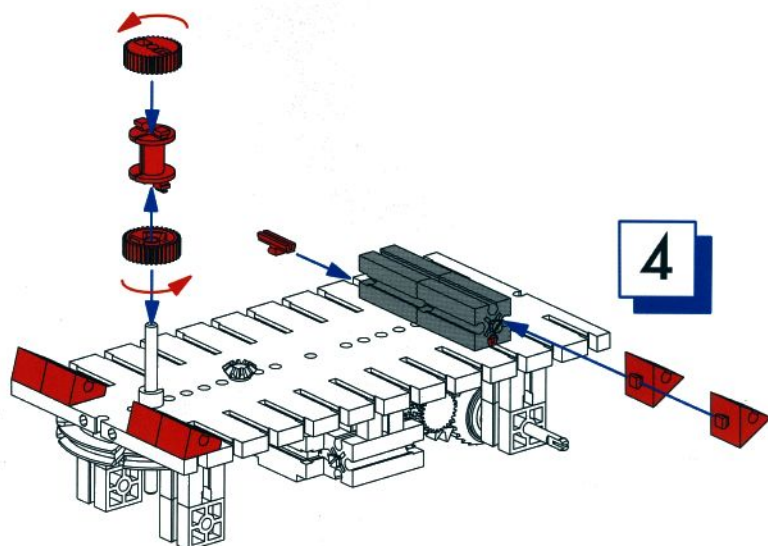
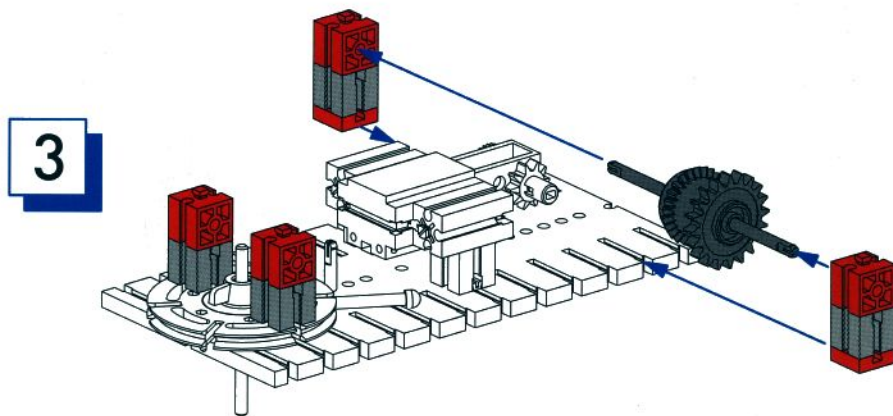
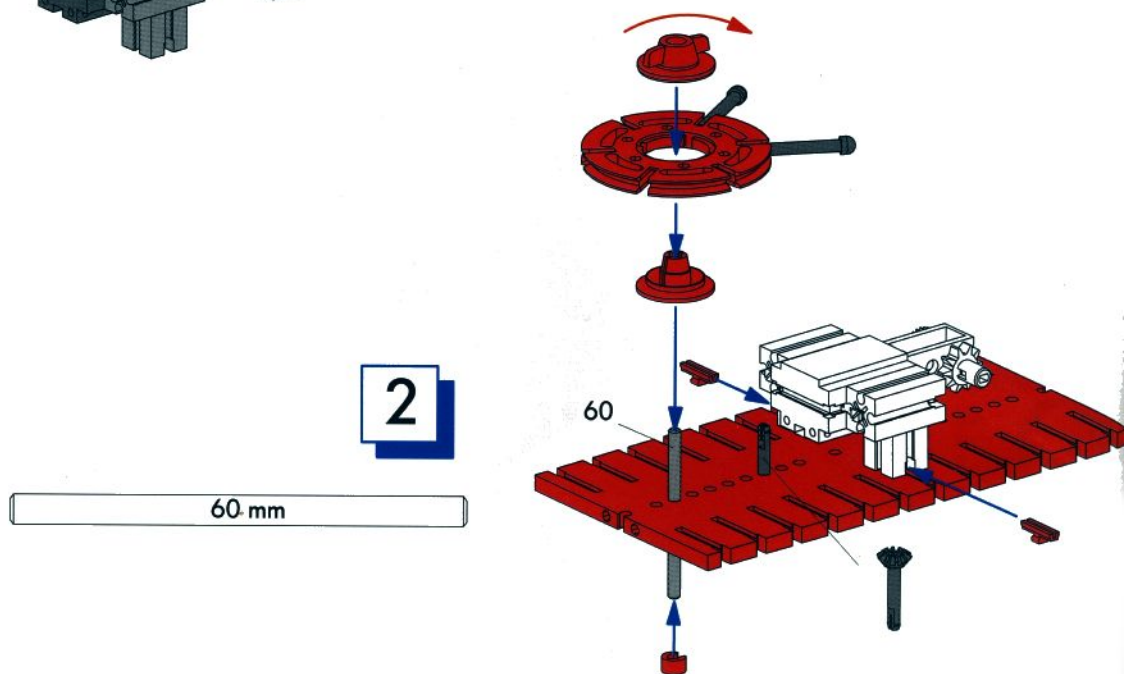
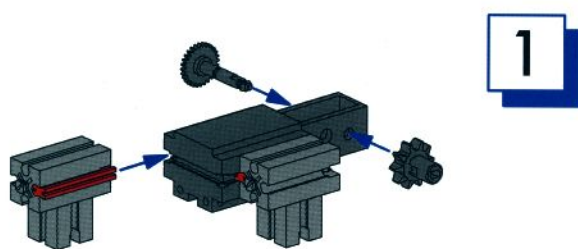

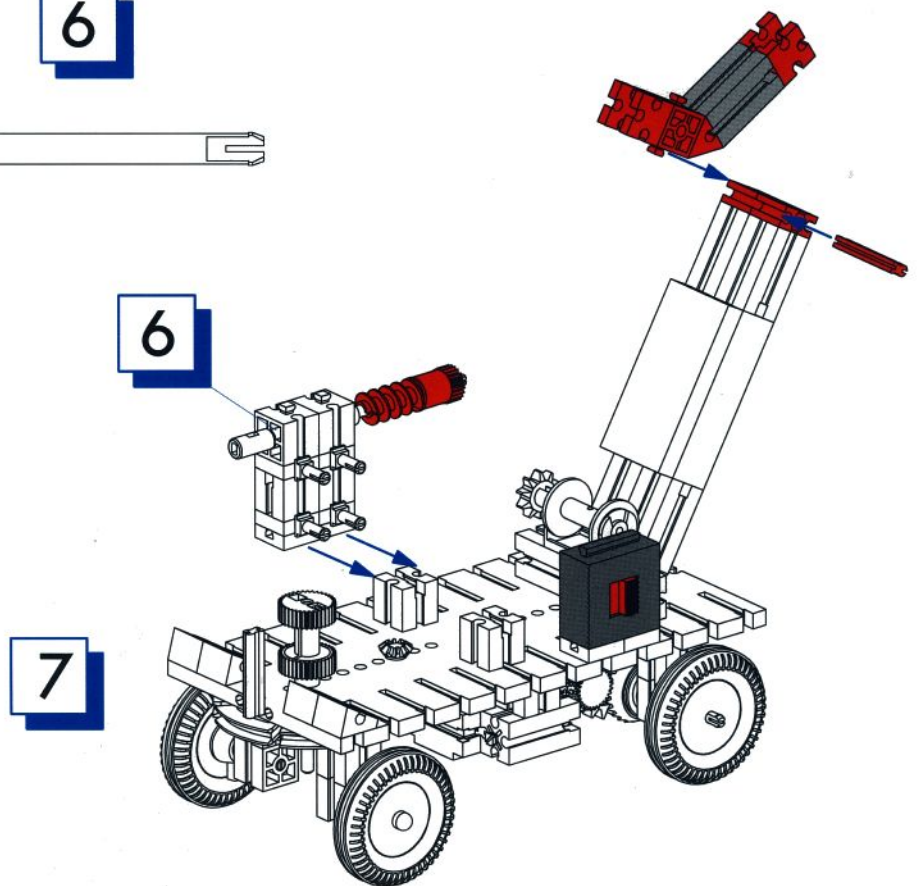
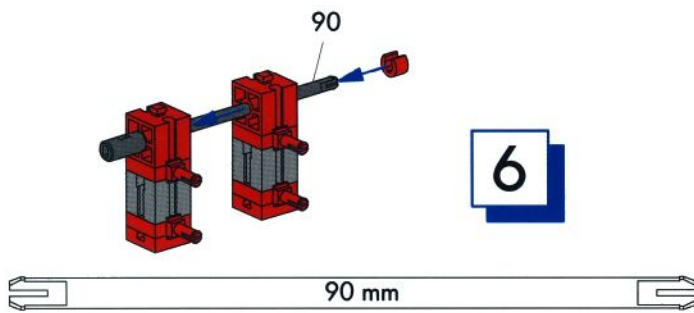
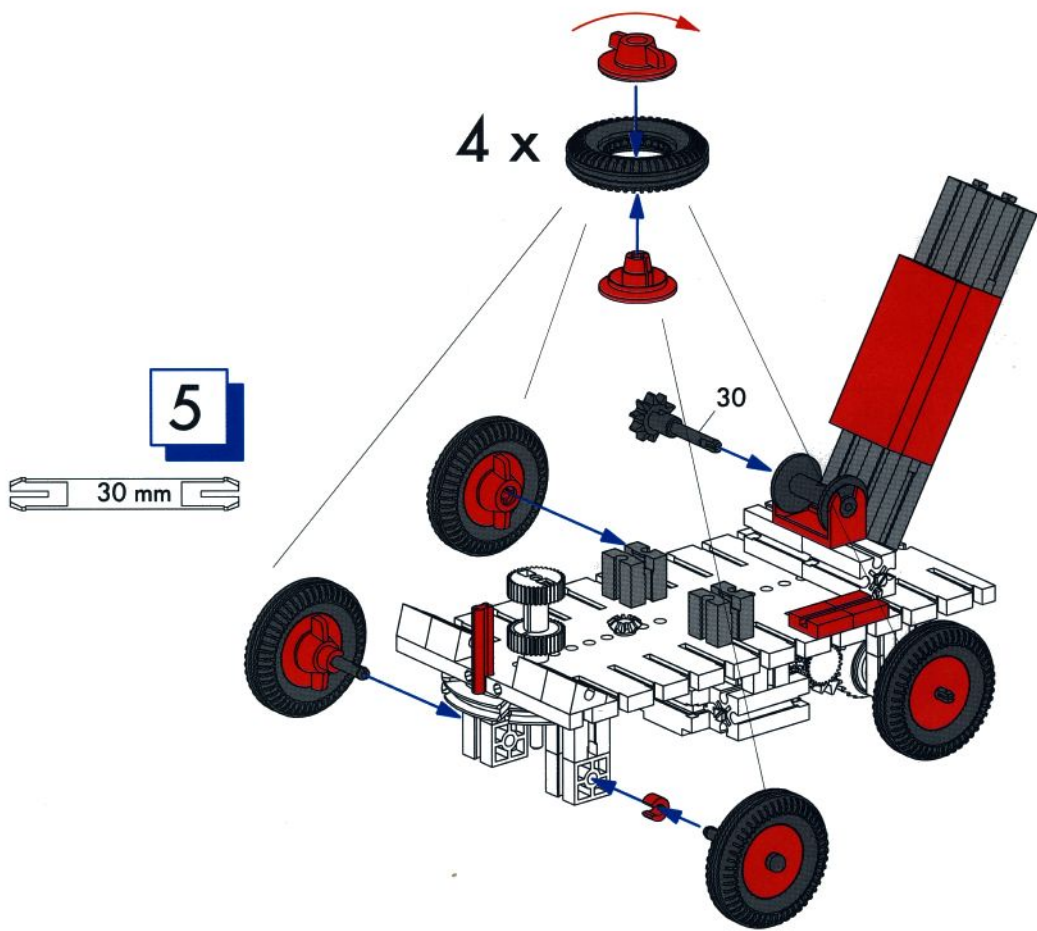





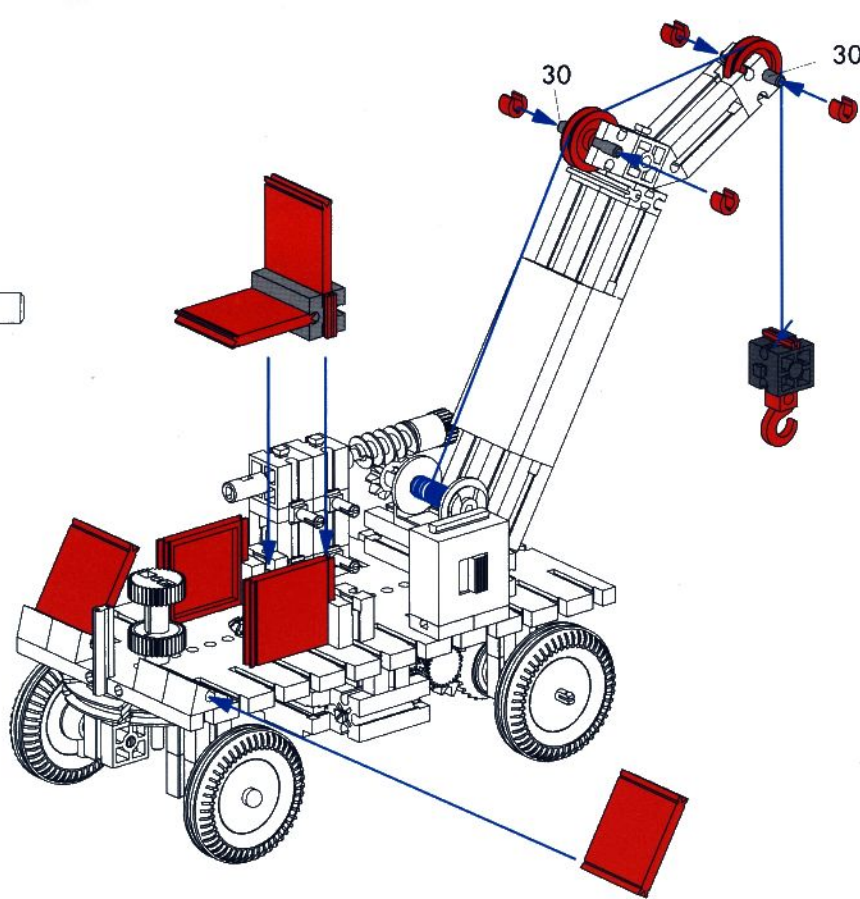











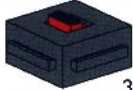

































8

30 mm



Einzelteilübersicht

 31 001	1 x	 31 034	2 x	 31 982	6 x	 35 063	1 x	 36 586	4 x
 31 003	10 x	 31 058	5 x	 32 064	7 x	 35 064	2 x	 36 708	1 x
 31 005	10 x	 31 061	4 x	 32 233	1 x	 35 066	1 x	 37 237	6 x
 31 010	3 x	 31 078	1 x	 32 263	1 x	 35 069	1 x	 37 468	2 x
 31 011	4 x	 31 082	1 x	 32 293	1 x	 35 070	1 x	 37 636	2 x
 31 013	6 x	 31 336	3 x	 32 321	1 x	 35 073	1 x	 37 679	8 x
 31 016	1 x	 31 337	3 x	 32 869	1 x	 35 795	2 x	 37 858	1 x
 31 018	4 x	 31 411	1 x	 32 870	4 x	 35 945	2 x	 38 225	1 x
 31 019	1 x	 31 412	2 x	 32 958	1 x	 35 982	1 x		
 31 020	2 x	 31 413	2 x	 35 031	5 x	 35 983	1 x		
 31 032	1 x	 31 915	1 x	 35 061	1 x	 36 382	1 x		